

Operator Manual



ELITE INDOOR STAIRLIFT

SRE-2010

04-19-2023

P/N 2010-O

Manual en español disponible en www.bruno.com



www.bruno.com

PRODUCT REGISTRATION FORM

THANK YOU! We appreciate you purchasing a Bruno stairlift! Your Bruno Elite stairlift is handcrafted in the USA and made specifically for your unique stairs.

Warranty Registration

Complete the warranty registration process by filling out the product registration form in one of two ways:

- Fill it out online at www.bruno.com/forms/product-registration
- Complete Product Registration Card enclosed with this product and return via mail

Serial Number

Please note the serial number of your stairlift is affixed to the stairlift. The serial and model number is needed for your dealer to file a warranty claim, request parts or to service the unit. We encourage you to keep this information.

Authorized Bruno Dealer

Bruno stairlifts must be installed and maintained by an authorized Bruno dealer or the warranty will be null and void.

Table of Contents

Regulatory Information and Specifications	3
Safety.....	4
Circuit Breaker	4
Operation	5-10
Standard Swivel Seat.....	6
Optional Power Swivel Seat.....	6
Optional Power Footrest	6
Optional Folding Rail	7
Optional Power Folding Rail	8-9
Diagnostic Codes.....	10
Charging	10
Battery Charger	11
Maintenance/Remote Battery Replacement and Interference	12
Vacation and Long-Term Storage	12
Troubleshooting.....	13
Warranty	14

REGULATORY INFORMATION and SPECIFICATIONS



This lift is intended to be installed in accordance with the current edition of:

- EN 81-40:2008 Safety rules for the construction and installation of lifts - Special lifts for the transport of persons and goods - Part 40: Stairlifts and inclined lifting platforms intended for persons with impaired mobility
- ASME A18.1:2017 Safety Standard for Platform Lifts and Stairway Chairlifts - Units with overspeed assembly
- ASME A18.1:2014 Safety Standard for Platform Lifts and Stairway Chairlifts - Units without overspeed assembly
- CAN/CSA-B613-00 (R2005) - Private Residence Lifts for Persons With Physical Disabilities
- ASME A17.5/CSA B44.1 - 2014 Elevator and Escalator Electrical Equipment
- NFPA 70: National Electrical Code®
- CSA C22.1 Canadian Electrical Code

Verify applicable local codes with the appropriate regulatory authorities.

Specifications

Weight Capacity: 400 lbs. (181 kg)

Control: constant pressure (armrest and two remotes)

Maximum Incline: 45° (specials to 50°)

Seat Swivel: 0, 60 and 90 degrees at the top; (optional) 45 degrees at the bottom

Battery Charger: 24VDC battery charger powered by 120V wall outlet.

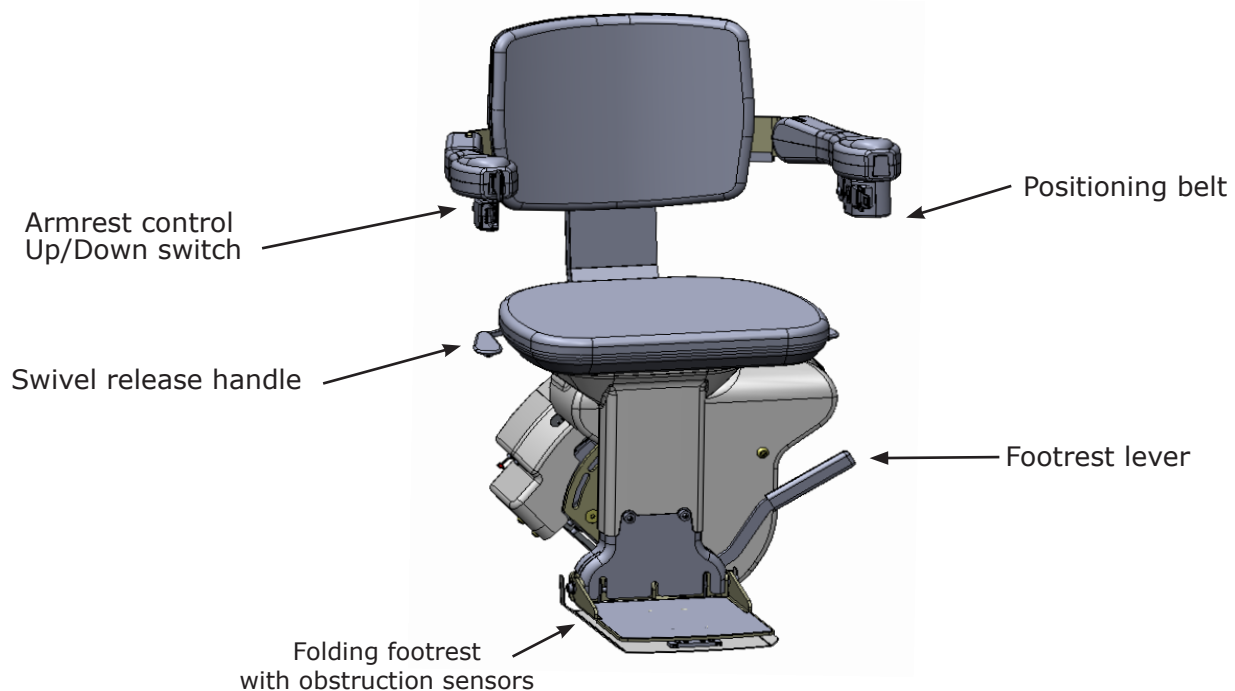

SAFETY/ CIRCUIT BREAKER

General Safety Tips

- Read and understand operating and safety precautions prior to using the stairlift.
- Clear stairs of objects before operating stairlift.
- Stay aware of surface onto which you are stepping as you get on/off the stairlift.
- Avoid carrying items on the stairlift which could hinder movement of the unit.
- Avoid loose clothing that could interfere with stairlift movement.
- Fasten positioning belt before operating stairlift.
- Ensure seat is locked in the correct riding position.
- Lock the swivel seat in place before getting on/off the stairlift
- Lean toward the upstairs for the smoothest ride if you cannot remain seated upright.

Non-ambulatory users: Carry a cellular or an emergency communication device when riding the stairlift alone in the house.

Safety Features

Speed: The stairlift is designed to travel down the stairway at a slightly slower speed than traveling up.

Obstruction sensors: Sensors in the stairlift footrest will stop the carriage if an obstacle is encountered on the stairs. If this should occur, press the opposite side of the armrest control switch to run the carriage in the opposite direction. Clear the obstacle and resume travel.

Power outage: Your stairlift is battery powered and will operate for some time during a power outage, depending on the battery condition, length of stairs and weight of rider. Only in the event of a prolonged power outage – more than one hour – will it be necessary to turn the power off (circuit breaker switch on the carriage) and turn off or unplug the charger from the wall outlet to conserve battery charge.

Power seat option: An overload sensor will prevent the seat from swiveling if a jam is detected.

Power footrest option: An overload sensor will cause the footrest to return to its last position if a jam is detected.

Power folding rail option: An overload sensor will prevent damage from occurring if an obstruction or jam is detected in the path of the moving folding rail section. The folding rail section will stop and briefly reverse direction if an obstruction is detected.

OPERATION

Bruno's stairlift features a "soft-start," preventing the unit from moving abruptly after the armrest control switch is pressed. Press and hold the armrest control to begin the gentle acceleration of the stairlift to operating speed. The stairlift will automatically stop at the upper or lower end of the rail or when the armrest control is released.

How to Operate Your Bruno Stairlift

- Position yourself in stairlift seat
- Fasten the positioning belt.
- Ensure the seat is in the proper riding position: rider back to the stairway wall
 - Raise and hold the seat swivel lever to rotate the seat to the "riding position," if needed.
 - Release the seat swivel lever to secure seat. The stairlift will not operate unless the seat is locked in the "riding position," a right angle to the rail.
- Position both feet on the footrest and arms on armrest cushions.
- Key switch units: Turn the key to ON position.
- Press and hold armrest control switch to travel up or down the rail.
- Raise and hold the seat swivel lever at top landing; rotate the seat to desired position.
- Release seat swivel lever and allow seat to lock in position.
- Key switch units: Turn the key to OFF position.
- Unbuckle positioning belt and carefully exit the seat.
- Fold armrests, seat and footrest when not in use, if preferred.

Note: Optional keyed switch units – Turning the armrest key to the OFF position disables both the arm control switch and the remote controls..

Wireless Remote Operation

You may also move your stairlift by using one of two remote controls included with your Bruno stairlift.

Note: The remotes are designed to call/send an empty stairlift only.

Wireless Remotes

The SRE-2010 hand-held remote may experience certain types of interference caused by portable and mobile radio frequency (RF) communications equipment. However, the SRE-2010 uses infrared (IR) communications to minimize the possibility of interference.

Also, receivers are mounted on both sides of the SRE-2010 carriage to minimize interference.

Should interference occur, the unit will stop. This feature has been integrated into the SRE-2010 to ensure your safety. The direct line between the remote to either of the two (2) remotes should be clear of obstacles for optimal operation. It may be necessary to reposition the remotes so that they are aimed at the carriage.

To reduce the possibility of interference:

- **Do not** allow direct sunlight to shine on the receivers (blinding the receivers on the carriage)
- Replace remote batteries regularly. Depleted or nearly-depleted batteries alter the effective range of the remote.
- Keep the remote and receiver lens free of dirt and debris.
 - Use a non-abrasive cleaner suitable for glass or acrylic surfaces.
 - Do not use polishes or cleaning products containing wax. These products will leave a film on the lens that will reduce the signal transmission range.

OPERATION: Power swivel seat /power footrest (optional)

Standard Swivel Seat

Swivel Positions: The Elite seat, with standard armrests, swivels a total of 90 degrees. The seat locks in three positions: the center "home" position and 60 and 90 degrees at the top landing. (Some installations allow the chair to swivel 45 degrees to the bottom landing.)

How to Rotate Seat:

- Swivel the seat at the top landing to safely exit away from the steps.
- Lift the release handle located under the seat (on either side of the chair). Once the swivel lever is released, the seat will lock in the closest 60- or 90-degree position.
- Unbuckle and carefully exit the seat

Flip-Up Seat:

- Save space on your stairs when your stairlift is not in use by flipping up the seat and armrests.

Power Swivel Seat Option

- Release the armrest control once your stairlift has stopped at the top landing.
- Engage the power swivel seat feature by pressing the armrest control again. (in the same direction you pressed to travel up the stairs).
- Release the armrest control switch once the seat has fully rotated.
- Unbuckle and carefully exit the seat.

Note:

- 1) The seat will swivel from 0-90 degrees **only** at the top of the stairway.
- 2) The remote control may be used to return the rotated power seat back to the ride position.

Power Footrest Option

An optional power footrest makes it easy to fold the stairlift footrest without leaning over.

- Raise the stairlift seat to the "stored" position, and the footrest will automatically fold up.
- Lower the seat, and the footrest will automatically fold down.
- Attempting to manually fold a power footrest option can damage the unit.

Note: If jam occurs when raising/lowering the footrest, clear the jam and move the seat up/down until the footrest moves again. If normal operation is not restored, please contact your Bruno dealer for service.

Note: Turning the armrest key to the OFF position disables both the arm control switch and the remote controls.

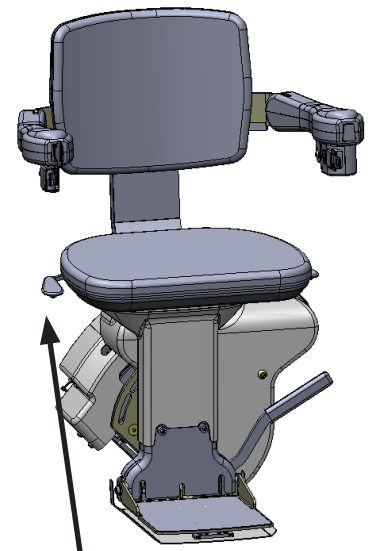

Swivel release handle

OPERATION: Manual folding rail (optional)

Optional Manual Folding Rail

Note: Stairlift must be in the mid-travel position or at the top landing position when folding the rail. Damage to the stairlift will occur if you attempt to fold the rail when the stairlift is lower than the mid-travel position.

How to fold rail up:

- Use handle to gently pull folding rail section up and toward the top of stairlift rail and then gently lower it.

How to fold rail down:

- Use folding rail handle to gently pull up and toward the bottom of the rail and lower the folding rail section to the ground. Do not allow the folding rail section to drop down into a lowered position

Note: If the carriage by-passes the mid-park while traveling in a downward direction and the **Folding Rail Carriage Safety Bracket** makes contact with the folded short rail, contact your local Bruno dealer for service.

 WARNING
PINCH POINT! Make sure the areas above and below the folding rail are clear before operating the folding rail. Keep children and pets at a safe distance.
Failure to observe this warning could result in injury or damage to equipment.

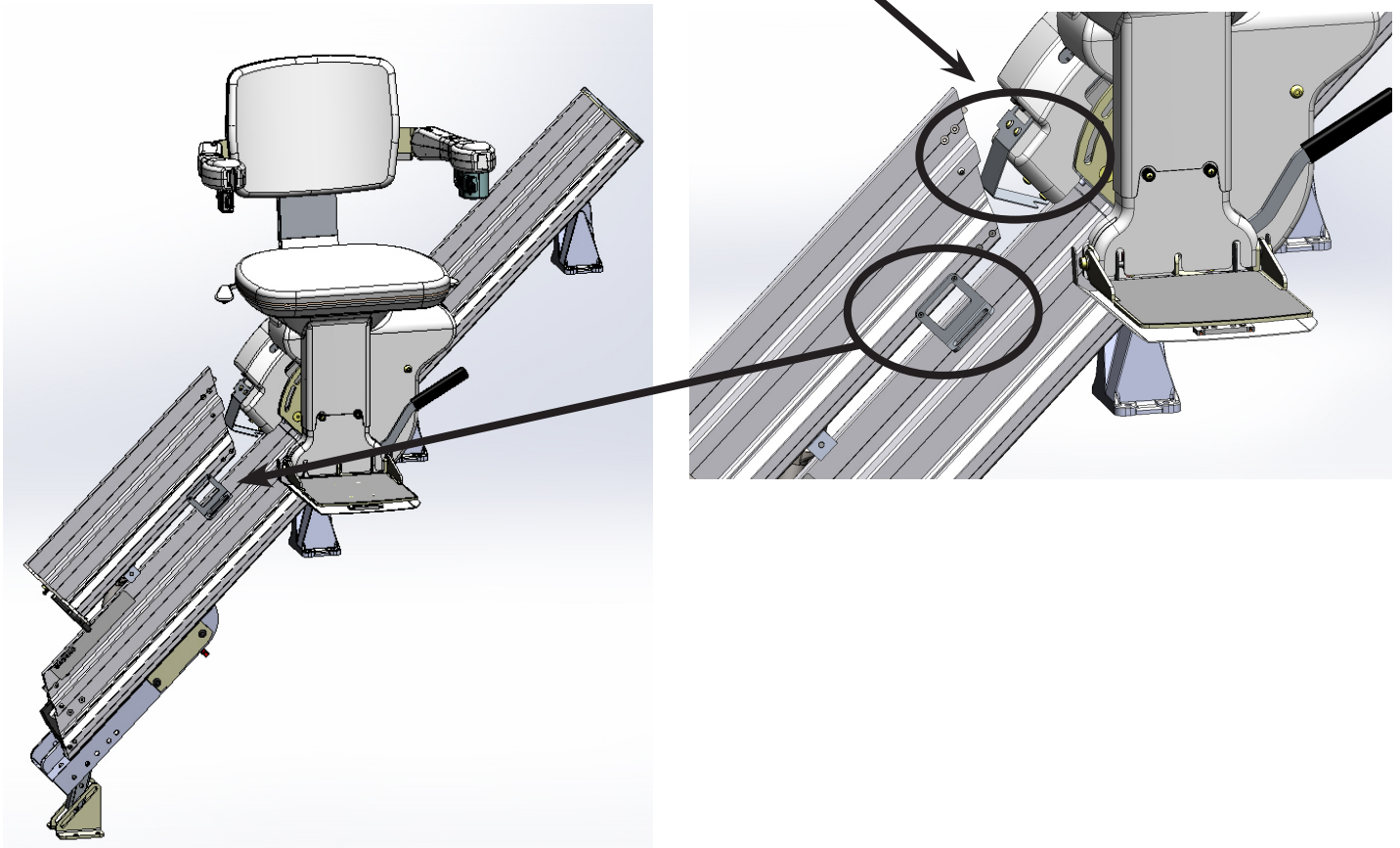

OPERATION: Power folding rail (optional)

 WARNING
PINCH POINT!
Make sure the areas above and below the folding rail are clear before operating the folding rail.
Keep children and pets at a safe distance.
Failure to observe this warning could result in injury or damage to equipment.

The **power** folding rail is very similar to the manual folding rail except it has a motorized actuation built into the rail hinge to automatically raise and lower the folding section of the rail.

The power folding rail includes a mid-travel stop position.

- If you are **above** this stop, the rail should always be **folded up**.
- If you are **below** this stop the rail should be **folded down**.

Do not attempt to manually fold the power rail!

Using power from the carriage, fold or unfold the rail:

- By riding the stairlift, or
- By using the remote controls

Riding the stairlift:

If you are at the top of the staircase, press the armrest control switch to ride down the rail until you contact the mid-stop, then release the switch. Look down the staircase to be sure there are no obstructions to prevent the rail from lowering!

Press the armrest switch again, in the down direction. The folding rail will lower. The stairlift will not move down until the rail folds down completely and touches the ground. Release the armrest switch once the rail reaches the ground. Once the rail is folded down, press and hold the armrest switch again until you reach the bottom of the staircase.

If you are at the bottom of the staircase, ride up until you contact the mid stop, then release the armrest switch. Look down the staircase to be sure there are no obstructions to prevent the rail from folding up. Press the armrest switch again, in the up direction. The rail will rise up. The stairlift will not continue up until the folding rail is completely folded up. When the rail is in its fully up position, release the UP armrest switch, then press it again to travel the rest of the way up the staircase.

Note: You will hear a continuous beep whenever the folding rail is in motion. This is to warn people nearby of rail operation. In addition, the yellow LED on the control panel flashes.

OPERATION: Power folding rail (optional)

Optional Power Folding Rail

Remote operation of power folding rail:

If you are at the bottom of the stairs, use your wireless remote to power the stairlift down the staircase. The folding rail will not lower until the chair contacts the "mid-travel" stop position. Once the stairlift has reached the mid-travel position, press the remote DOWN button again to unfold the rail. If you want to store the stairlift with the rail folded up, use the remote to send the stairlift to the "mid-travel" position. Then press the remote UP button again to raise the rail.

Note: Be sure to stand clear of the rail as it unfolds!

Safety features of power folding rail:

To reduce the chance of injury to people, pets and property, the optional power folding rail is equipped with an obstruction safety system. If the power folding rail detects an obstruction, the rail will stop and briefly reverse direction.

- Press the armrest control switch or remote in opposite direction
- Clear the obstruction
- Press the armrest control switch or remote again, in the desired direction

Disable switch:

The control panel, located on the folding rail, includes a disable switch. Pressing the switch off prevents the rail from folding up or down. Use this function if you wanted to keep the rail folded down for an extended period. Press the switch to on to allow the rail to fold and unfold correctly under power.

EMERGENCY ONLY!

Should you need to raise or lower the power folding rail and you are unable to do so using the armrest up/down control switch or the remote, switch the disable switch to OFF. Manually and **gently**, raise or lower the rail at the location marked with * below. Make sure to lift slowly where indicated below. Lifting the rail in a quick motion may result in damage to the folding rail gearbox.

Note: If the carriage by-passes the mid-park while traveling in a downward direction and the **Folding Rail Carriage Safety Bracket** makes contact with the folded short rail, contact your local Bruno dealer for service.

⚠ WARNING
PINCH POINT!
Make sure the areas above and below the folding rail are clear before operating the folding rail.
Keep children and pets at a safe distance.
Failure to observe this warning could result in injury or damage to equipment.

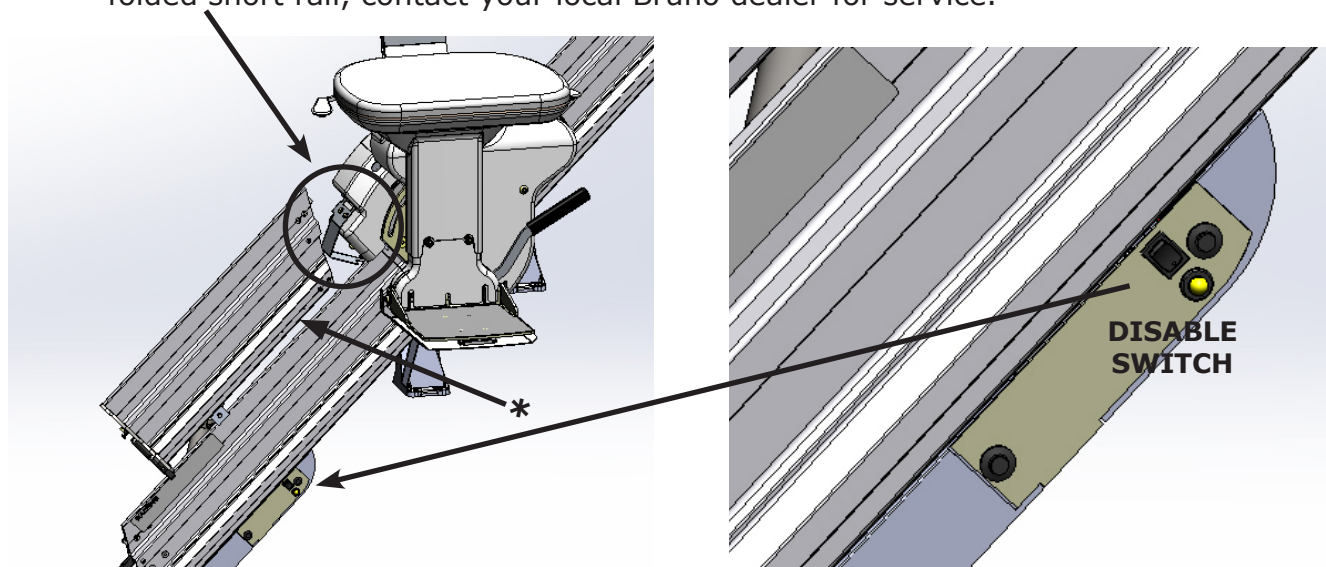

DIAGNOSTIC CODES (underseat) and CHARGING

A2	Seat in UP Position (Seat Fold Switch Closed)
A3	Seat Out of Riding Position (Swivel Limit Open)
A7	Seat or Footrest Jammed (Actuator Stalled)
C1	Charging
C2	Off Charge (Running)
C4	Parked and Charger Not Detected
C5	Battery Voltage Critical (Charge Immediately)
C6	Battery Voltage Low
L1	Seat Safety Switch Open
L2	Up Limit Switch Open
L3	Down Limit Switch Open
L6	Mid-Rail Park Active
L8	Soft Stop Switch

Charging



Keeping Stairlift Charged

Bruno stairlifts are powered by two 12v batteries that charge when the lift is parked anywhere on the rail.

Failure to keep the batteries charged, or allowing them to fully discharge, will significantly shorten battery life.

The power light should always be displayed, meaning the outlet is giving the charger power (the light should be on even if the unit is off). Either a yellow charge light or green "float mode" light will be lit indicating the unit is charging.

BATTERY CHARGER

LEDS

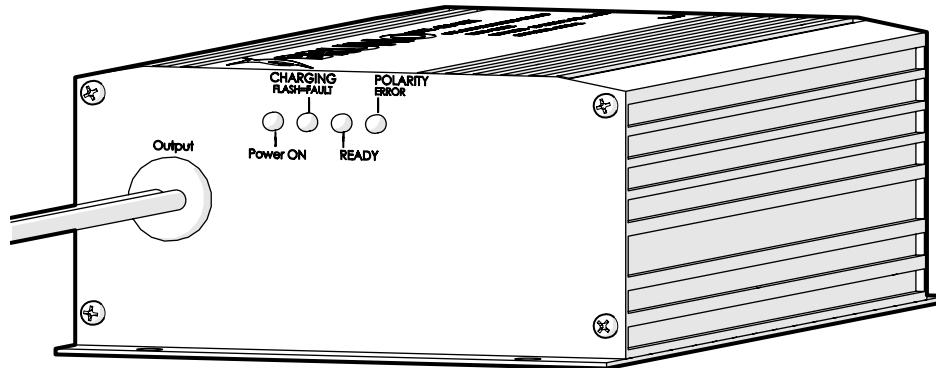

RED	YELLOW	GREEN	BLUE	STATUS
ON	ON (< 1 sec.) OFF	OFF	OFF	charger not connected to battery
ON (<5 sec.) ON ON	ON (<5 sec.) OFF OFF	ON (<5 sec.) BLINK (5 sec.) OFF	OFF	battery disconnect situation detected; 5-second delay until yellow and green LED's completely off
ON	ON	OFF	OFF	charger delivering maximum current (2.2A)
ON	ON	OFF	OFF	charger at maximum voltage; current continues to drop
ON	OFF	ON	OFF	batteries fully charged; yellow LED occasionally turns off
ON	BLINKS ALTERNATELY	BLINKS ALTERNATELY	OFF	low voltage indication
BLINKS ALTERNATELY	BLINKS ALTERNATELY	OFF	OFF	battery defective or heavily sulfated
ON	OFF	FAST BLINK	OFF	partially open circuit; bad contact or battery sulfation
			ON	battery connector reversed

MAINTENANCE & LONG TERM STORAGE

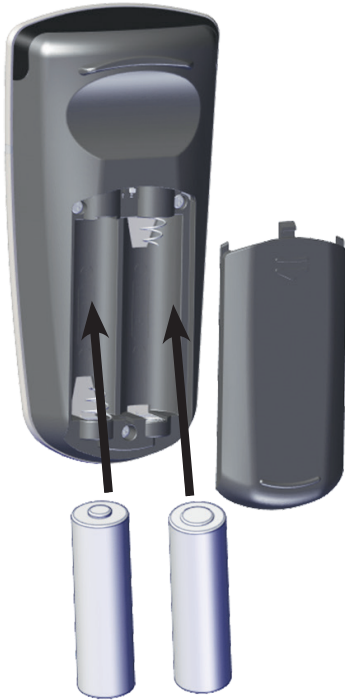

Back of remote control
with battery access
cover removed

General Maintenance Tips

- Keep the rail channel clean and free of debris.
- Keep battery charger plugged into a live outlet.
- Contact your Bruno dealer annually to have the stairlift examined, cleaned and lubricated.

Remote Battery Replacement

- Remove access panel on back.
- Replace two AA alkaline batteries.
- Change batteries annually.

Vacation and Long-Term Storage

- Turn off the circuit breaker (ON/OFF switch near the seat).
- Unplug the battery charger from the wall.

Once you are ready for the stairlift to return to action, make sure the batteries are charged and rail free of dust.

- Reconnect the charger to the wall outlet.
- Turn on the main power switch on the stairlift carriage.
- Wait until the LED light on the charger turns green to depict full battery charge.
- Dust rail with wax-based cleaner, such as Pledge®.

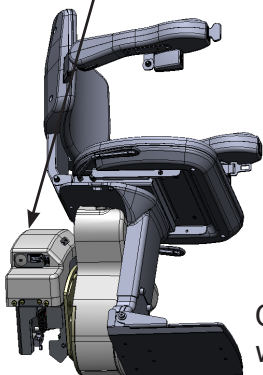
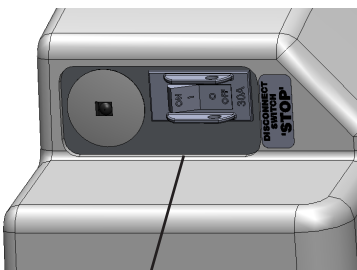

ON/OFF switch
with built-in
circuit breaker

Circuit Breaker Note

The stairlift includes an ON/OFF switch with a built-in circuit breaker that protects the battery, controller and motor circuits in the stairlift carriage. It is unlikely the circuit breaker will trip. However, if the stairlift becomes inoperative, check the circuit breaker and reset if needed.

Possible causes of circuit breaker tripping:

- Foreign object jamming the rail or gear rack.
- Exceeding the rated weight capacity of the stairlift.

Stairlift Beeps at Top of Stairs When Seat Rotated

All Bruno stairlifts are shipped in "multi-user mode" which causes the stairlift to beep at the top landing when the seat is turned. This safety feature alerts a second user that the seat is swiveled. Rotate the seat so it clicks and "locks" back into its original riding position and the beeping will stop. Your Bruno dealer can also switch the stairlift to "single user mode" which will disable the beeping safety feature.

Stairlift Operates Very Slowly

If the batteries on your stairlift are low, the stairlift will move slowly and/or stop. Partially charged batteries will allow the stairlift to go down the rail but not up. If the stairlift continues to run slow or stops, please contact a Bruno dealer to replace batteries.

Stairlift Will Not Operate

- Check the LED lights on the charger.
 - Green light shows batteries fully charged.
 - Yellow light means stairlift is charging.
 - Red light depicts charger receiving electricity, but stairlift not receiving power. For example, the charge strips may be dirty or a wire is disconnected between charger and rail.

Possible Electrical Issues:

- Check on/off switch on the side of the stairlift seat to make sure it's in the "on" position. Flip switch "on/off" to reset.
- Look at diagnostic display under seat. Press an arm switch or remote. If nothing displays, there is no power to the unit.
- Validate the stairlift charger is plugged into a wall outlet.
- Ensure the wall outlet is working by hooking up a lamp or other device.
- Check that a main circuit breaker in your home has not been tripped or fuse blown (in fuse box of your home).
- Inspect that the cord is not plugged into a "switched" outlet that only receives current when light switch is turned on.

Keyed Stairlift Units: Make sure key is in "on" position.

Possible Safety Trigger:

- Clear stairs of any objects that may cause the obstruction safety sensors in footrest to stop lift.

Bruno Dealer

Please call your local Bruno dealer for annual maintenance on your stairlift or if you need other service on your Elite stairlift.

Limited Lifetime Major Components — 2 Year Parts

Bruno Independent Living Aids, Inc. (Bruno) is confident in its USA-designed and built stairlift units and is pleased to provide the Original Purchaser of a Bruno Stairlift with the following "Industry Leading" warranty.

The quality of parts used, along with the care of Bruno's employees in constructing Bruno's products, allow Bruno to provide the following warranty coverage to the Original Purchaser of the Bruno Stairlift:

- All Parts, other than Major Components, are/will be free of defects in material and workmanship for a period of two (2) years after the date of installation by a Bruno Authorized Dealer.
- All Major Components, including the motor, gearbox, drivetrain, and static rail system of the Bruno Stairlift, are/will be free of defects in material and workmanship for the lifetime of the Bruno Stairlift and as long as the Original Purchaser owns the Stairlift. Major components do not include optional equipment.
- All labor, to be provided by a Bruno Authorized Dealer, to address any defect of the Bruno Stairlift is covered for the first thirty (30) days after installation thereof by a Bruno Authorized Dealer.
- All Bruno warranties begin on the date of installation of the Bruno Stairlift by a Bruno Authorized Dealer, but that date should be no later than 14 months after it was shipped from the factory.

Bruno Authorized Dealers are trained to evaluate your unique situation and then install the best Bruno Stairlift to meet your needs. The trained installation and service technicians employed by a Bruno Authorized Dealer have the appropriate equipment and resources needed to correctly install and maintain the Bruno Stairlift and should be the first contact for any warranty or service needs.

WHAT IS NOT WARRANTY COVERAGE:

- Damage to units caused by misuse, abuse, accidents, neglect or modifications NOT made by a Bruno Authorized Dealer.
- Consumable items such as remote batteries
- All labor by a Bruno Authorized Dealer after the first thirty (30) days since installation.
- Reasonable wear and tear.

ADDITIONAL NOTES:

- All Service and Warranty claims must be brought to the attention of a Bruno Authorized Dealer. To ensure warranty coverage, all maintenance and repair work on the Bruno Stairlift, other than maintenance provided by the Original Purchaser as called for in the Operator's Manual, must be performed by a Bruno Authorized Dealer.
- In no event shall Bruno be responsible for indirect, incidental or consequential damages, whether such damages arise based on claims based on contract, warranty, tort (including negligence, strict liability or product liability).
- Bruno, at its sole discretion, reserves the right to replace, repair, or, if not commercially practical and/or feasible, elect to refund the Original Purchaser the purchase price of the Bruno Stairlift.
- This warranty gives the Original Purchaser specific legal rights for which the Original Purchaser may also have other rights that vary from state to state. Bruno specifically does not authorize any person to extend the time or scope of this warranty.

For further information regarding this limited warranty, please contact Bruno using the contact information shown below:

North America

Bruno Independent Living Aids, Inc.
Attn: Service Department
1780 Executive Drive
Oconomowoc, WI 53066
United States
Tel. 1-800-882-8183 toll free

UK and Europe

Bruno
Unit 5, Millennium Court
Clayhill Industrial Park
Neston, Wirral CH64 3UZ
United Kingdom
Tel. 0151 559 0732

